

For the professional user

Operating Instructions

Für den professionellen Anwender

Betriebsanleitung

Class: 560-31
Klasse:

Model:
Ausführung: 2

Dated:
Stand:

Strobel clients know that they can expect a particularly high standard of performance from our company and our machines. Now you have settled for one of our products. For us this is a source of encouragement and of obligation to Justify your trust.

If you wish to profit from the performance and efficiency of your Strobel machine as long as possible, exact handling and thorough care is necessary. For this reason we kindly request that you read the operating instructions closely.

It provides all the information you need for trouble free operation.

And if you do happen to need a spare part the enclosed spare parts list gives a complete overview. It is clearly classified according to components so that you can find the required part quickly and easily. In order to avoid errors we request you to quote machine class, machine number and part number completely on your spare part order.

We wish you lots of success in your work with your new Strobel machine.

The sign of quality



You find the Strobel trademark on every Strobel machine leaving our works. And with good reason. This symbol is a guarantee of the high quality of our products. Quality which creates trust – trust in our technology, our service and, not least of all, in our good name.

Im Zeichen der Qualität

S*ie finden die Strobel-Schutzmarke auf jeder Strobel-Maschine, die unser Werk verlässt. Und das aus gutem Grund. Denn dieses Zeichen garantiert Ihnen die hohe Qualität unserer Produkte. Qualität, die Vertrauen schafft – in unsere Technik, unseren Service und nicht zuletzt in unseren guten Namen.*

Garantiekarte/Warranty Sheet

STROBEL

Boschstraße 16
D-82178 Puchheim
Tel.: 089/80096-0
Fax: 089/80096-190
info@strobel.biz

Maschinenklasse/Machine class: _____

Serien-Nr./Serial No: _____

Auftrags-Nr./Order Confirmation No: _____

Lieferdatum/Delivery Date: _____

Rechnungs-Nr./Invoice No: _____

Rechnungsdatum/Invoice Date: _____

Beanstandung/Complaint: _____

Datum/Date

Unterschrift/Signature:

Bitte nicht vom Kunden ausfüllen/To be filled out by Strobel:

	Datum	Bemerkung
EXA:		
ETA:		
PROD:		
EXA:		
BH:		

Operating instructions STROBEL series 560-31

Contents

1	General notes on safety	3
2	General	5
2.1	Operating instructions	5
2.2	Class description, serial number and initial basis for description	5
2.3	Range of application and intended use	5
2.4	Power supply.....	5
2.4.1	General notes.....	5
2.5	Technical Data.....	6
3	Installation and putting into service	8
3.1	Unpacking the machine	8
3.2	Installation (Fig. 1).....	8
3.3	Sense of rotation.....	10
3.4	Motor drive via Toothed belts	10
3.4.1	Tensioning the V-belt (Fig. 2).....	10
3.4.2	Positioning the machine (Fig. 4)	11
4	Instructions for use.....	13
4.1	Needles and threads	13
4.2	Inserting the needle (Fig. 5)	14
4.3	Threading and thread course.....	15
4.4	Thread tension (upper thread tension)	17
4.4.1	Setting the thread length at the beginning of the seam (lower thread tension).....	17
4.5	Stitch depth.....	17
4.5.1	Setting the stitch depth	17
4.6	Sewing drive	17
4.7	Use of the variable sewing tools.....	18
5	Operating the machine.....	20
5.1	Switching on (Fig. 1)	20
5.2	Inserting and removing the material (Fig. 9)	20
5.3	Sewing	21
5.3.1	Sewing process (Fig. 9).....	21
6	Operating and function of the control	22
6.1	General.....	22
6.2	Control and display elements OP1000 (Fig. 11)	23
6.2.1	Pedal step "sewing start"	24

6.3	Failures	25
7	Machine maintenance.....	27
8	Variable sewing tools	27
9	Optional extras	30
9.1	Special version for lapel points	30

Subject to change without prior notice

1 General notes on safety

Manuals and additional information can be found on the STROBEL website at:

<http://www.strobel.biz>

Every person in charge of setting up, operating, servicing and repairing the machine must first read and understand the operating instructions and particularly the safety instructions before starting up the machine.

Failure to comply with the following safety instructions can lead to physical injuries or damage to the machine.

1. The machine must only be operated by persons familiar with the relevant operating instructions and who have been instructed accordingly.
2. Before commissioning also read the notes on safety and the operating instructions of the sewing drive manufacturer.
3. Only use the machine in the intended manner and never without the provided guards. Always observe the pertinent safety regulations.
4. Switch off the main switch or pull the power plug for threading, changing the bobbin, exchanging sewing tools such as needle, hook, stitch plate, transport devices, trimming knife and cutting block, for cleaning and when leaving the workplace as well as for maintenance.
5. General maintenance tasks may be carried out only by properly trained persons in accordance with the operating instructions.
6. Repair work, retrofitting and maintenance may be carried out only by technicians or specially trained personnel.
7. When servicing or repairing pneumatic equipment, the machine must be disconnected from the pneumatic supply. Exceptions are only allowed for adjustment work and tests of functionality performed by specially trained technicians.
8. Only specially qualified technicians may work on the electrical equipment.
9. It is forbidden to work on electrically live components! Exemptions are covered by the EN50110 (DIN VDE0105) regulations.
10. Any retrofitting or alterations to the machine may only be performed under strict compliance with all pertinent safety regulations.
11. Only use our approved spare parts when servicing and/or repairing the machine.
12. It is forbidden to operate the sewing head until it is determined that the entire sewing unit complies with EU provisions.

13. It is essential that you observe and follow these instructions as well as the generally valid safety regulations.
14. Warning instructions given in the operating instructions that pertain to especially dangerous parts of the machine must be indicated at these positions using a safety symbol.



Warning instructions given in the operating instructions that pertain to special injury hazards for operating personnel or technicians must be indicated at these positions using a safety symbol.



2 General

2.1 Operating instructions

Any person involved in the installation, operation, maintenance and repair of the machine must have read and understood the operating instructions and mainly the safety instructions before starting the machine.

2.2 Class description, serial number and initial basis for description

For side-referenced descriptions, the operating side of the machine is the starting base.

The class descriptions (type), the serial and model number (after the hyphen) can be found on the rating plate on the right hand side of the housing.

2.3 Range of application and intended use

Automatic single thread blindstitch spot tacking machine for attaching woven labels, as well as for attaching linings, hems, trouser turn-ups and seams.

All machines are equipped with fully automatic control of the sewing process, preselection of 1 to 20 (max. 255) spot tacking stitches, thread trimmer and pneumatic lifting.

2.4 Power supply

2.4.1 General notes



CAUTION !











Work on the sewing machine's electrical equipment or sewing drive may only be done by electricians!

There is the **DANGER** of a fatal electrical shock.

When working on the electrical equipment, the machine with the S1 power switch has to be switched off and the power plug pulled out!

The operating instructions (including safety instructions) of the sewing machine and sewing drive must be observed!

2.5 Technical Data

	Empfohlene Nennstichzahl / Recommended rated speed	1200 min-1
	Stichzahl je Riegel / stitches per tack	6 - 14 Auslieferungszustand 8 Stiche pro Riegel / delivery condition 8 stitches per tack
	Stichplattenöffnung / needle plate opening	8,0 mm 4,5 mm optional 6,0 mm optional 10,0 mm optional
	Zusatzausstattung für Schulterpolster, Fassonspitzen, Krawattenetiketten als option Additional equipment for shoulderpads, lapel points and labels for ties on request	optional
	gefederter Taucher / spring loaded plunger	Auswahl der Taucher 281.0191 und 281.0188 für verschiedene Anwendungen / Selection of plunger 281.0191 and 281.0188 for various applications
	Nadelpendelung / needle oscillation	
	Nadelsystem / needle system Nadelstärke / needle size	GROZ-BECKERT 1717 VRUE 90/14
	Fadenabschneider / thread trimmer	
	2 Fadenspannungen / 2 thread tensions Faden / thread	Polyester Umspinnzwirn / polyester core spun 80
	runde Arbeitsplatte / round workplate	optional Durchmesser / diameter 130 mm
	LED Leuchte / LED sewing lamp	

Technischer Auslieferungszustand / delivery condition:	
Anzahl der Riegelstiche / number of stitches	6, 8, 10, 12, 14
Motor-Leistung min. / min. motor power	500 W / DA432
Zahnriemenscheibe Maschine / toothed belt pulley/machine	Z = 38
Zahnriemenprofil / toothed belt profile	HTD 5M-9
Stichart / stitch type	Einfaden-Blindstich- Punktriegel Typ 101 single thread blind stitch spot tacking type 101
Anschluss pneumatisch / pneumatic connection	6 bar
Luftverbrauch, Mittelwert / avarage air consumption	290 l / h
Stellfläche / foot print	0,5 m x 1,1 m
Arbeitsgeräusch / operating noise at 1200 min-1 nach DIN 45635-48-1 KL3	LpAm 72 dB(A)

3 Installation and putting into service

3.1 Unpacking the machine

The machines of series 560-11 and -21 are supplied as complete units with stands only.

The Reel stand and another machine accessories located into the packaging.

Make sure that all accessories have been unpacked before throwing away any packing material.

3.2 Installation (Fig. 1)



C A U T I O N ! Danger of injury!

Danger of bodily injuries or finger bruises through pulling in of garments or hairs!

The machine may not be operated without belt guards for head and motor.

The electrical connection must be carried out according to the marking of the cable or the supplied wiring diagram.

Check if all screws on the stand are tight and retighten them, if necessary.

Before putting the machine into service make sure that the electrical connecting data on the motor's name plate, your electric network and the frequency, and all other connecting values, e.g. for the air, correspond to the data shown on the machine and the operating instructions.

Since feed cup opening and some other operations are realized pneumatically, a compressed air connection of 6 bar is required (see point "2.5 Technical Data"). Regulation of the pressure by means of compressed air conditioner.



A T T E N T I O N !

Before putting the machine into service make sure that the electrical connecting data on the motor's name plate, your electric network, and all other connecting values, e. g. for the air correspond to the data shown on the machine and the operating instructions.

Fig. 1

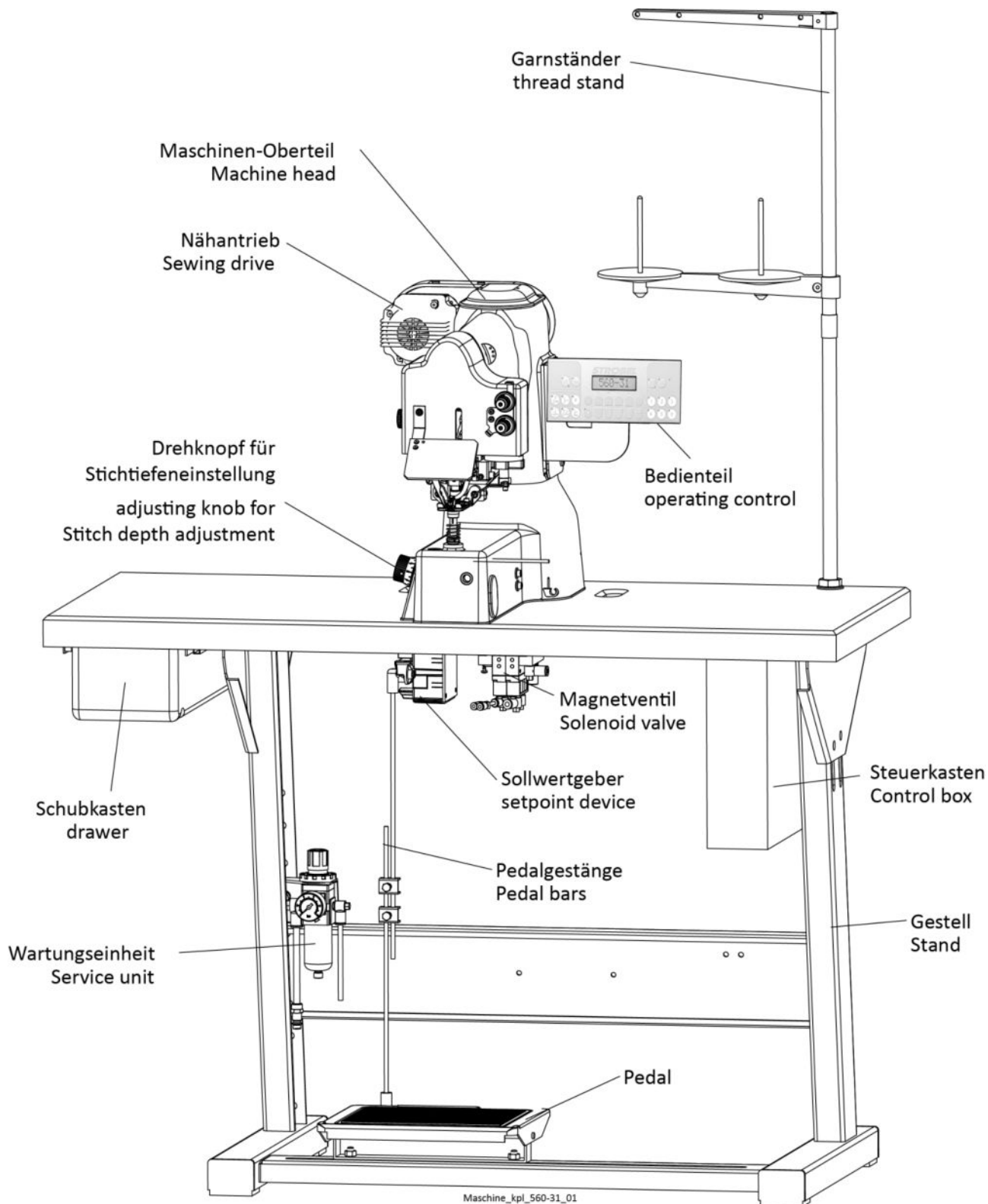

3.3 Sense of rotation

The correct sense of rotation of the hand wheel is clockwise in line of vision on the hand wheel.

3.4 Motor drive via Toothed belts

3.4.1 Tensioning the V-belt (Fig. 2)

	<p>CAUTION ! Danger of injury!</p> <p>To check the tooth-belt's tension, switch off the machine electrically and pull out the power plug. Press the motor pedal then to make sure that the machine is really at stand still.</p> <p>The machine may not be operated without belt protection for the motor.</p>
---	---

The tooth-belt should not be tensioned too tight. You should be able to compress it easily with your thumb by about 5 mm.

Too little or too great tooth-belt tension can be bad for the machine's positioning and thus impair the function sequence.

Tension the tooth-belt (Fig. 2):

- Loosen the upper and lower fastening screws (1), (2) on the machine upper part.
- Pull motor out a little and slightly tighten the lower fastening screw (2).
- Tension the tooth-belt by swivelling the motor.
- Tighten the upper and lower fastening screws (1), (2) again.

Fig. 2

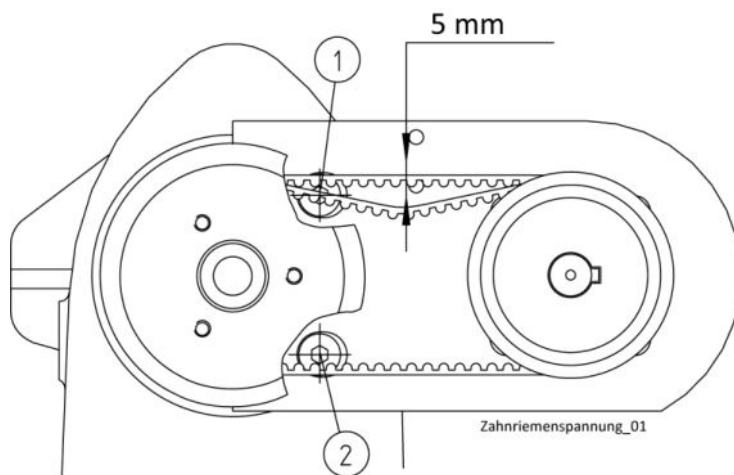

3.4.2 Positioning the machine (Fig.3)

	<p>CAUTION ! Danger of injury!</p> <p>Danger of pulling in parts of clothing and of hair and danger of crushing fingers and stitching fingers with needles!</p> <p>When checking positions with switched-on machine keep fingers and hands away from moving parts.</p>
---	--

The machine needs a reference position and a cutting position.

Reference position t 80 10:

The reference position must be set in such a way that the tip of the needle is flush with the inner edge of the needle glide plate during right-hand penetration.

Fig. 3

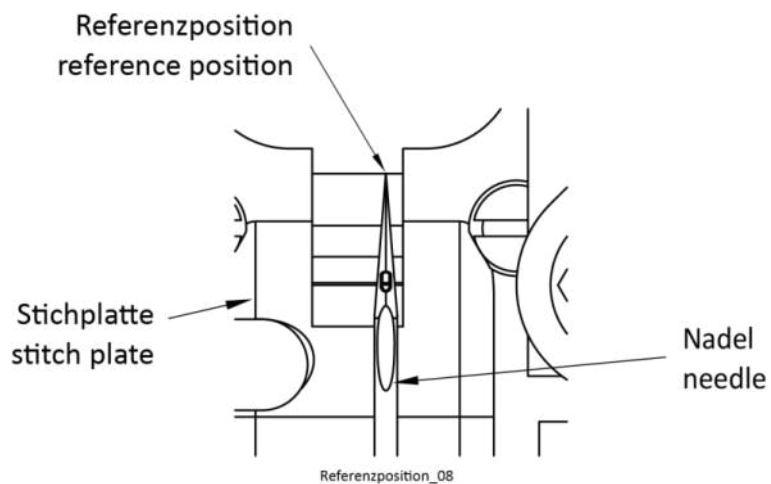

Cutting position:

The cutting position must be set so that there is a distance of 1 to 1.5 mm between the two when the stitch is out at the right side, and when the hook (1) is at a standstill and the movable knife (2) is swivelling (Fig.3).

Fig. 4

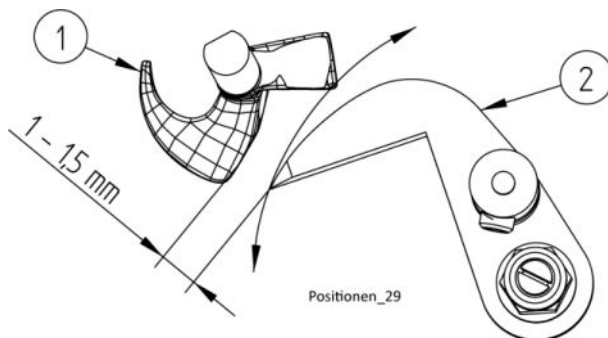

Position 2 is the cutting position and was set for this sewing machine as follows:

t 08 12 = 262

t 08 13 = 262

The values may deviate by a few increments depending on the machine and can simply be readjusted. Please note! t 08 12 and t 08 13 must always be set to the same value.

Please note:

If the cutting position is set correctly, a sewing cycle always starts with the left-hand stitch!

4 Instructions for use

4.1 Needles and threads

The sewing quality can be influenced to a considerable extent by choosing the most suitable needles and threads for the material to be sewn. It is recommended to use checked GROZ-BECKERT needles system 1717 VRUE only.

The machine is supplied with size 90/14 needles.

NOTICE: A perfect needle is of great importance for a good blindstitch. Damages of the needle point which often can be made visible under a magnifier only may deteriorate the sewing result. Replace your needle in time!

We recommend polyester core spun of size 80. Because of their high strength and ability to slide with a low thread volume they are to be preferred over a spun thread.

For special applications also transparent monofil nylon threads or covering yarns can be used.



G u a r a n t e e d r e m a r k !

This machine has been set and sewn off with **genuine GROZ-BECKERT needles**.

No guarantee can be granted if the settings are modified for using different needle types.

4.2 Inserting the needle (Fig. 5)



CAUTION ! Danger of injury!

Before replacing the needle, switch off the machine electrically, and depress the motor switch pedal to make sure that the machine is truly switched off.

Otherwise there is a **danger of injury** from crushing and needle punctures.

The needle shape determines its position in the needle lever. Attention should be paid only to ensure that the needle piston in the prisma of the needle lever is pushed to the stop and that screw (2) of needle clamping plate (1) is tightened well.

Fig. 5

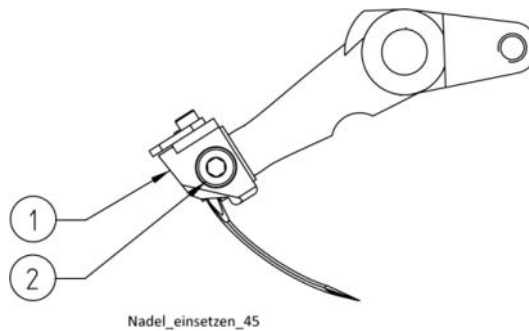

4.3 Threading and thread course

	<p>CAUTION ! Danger of injury!</p> <p>Switch off machine electrically and confirm that the machine is really in standstill position by operating the treadle for the motor control before threading.</p>
---	---

Fig. 7 shows the correct threading.

Pull monofile threads once (Fig. 6b) and all other threads three times (Fig. 6a) through the guide at the machine head.

Fig. 6



Fig. 7

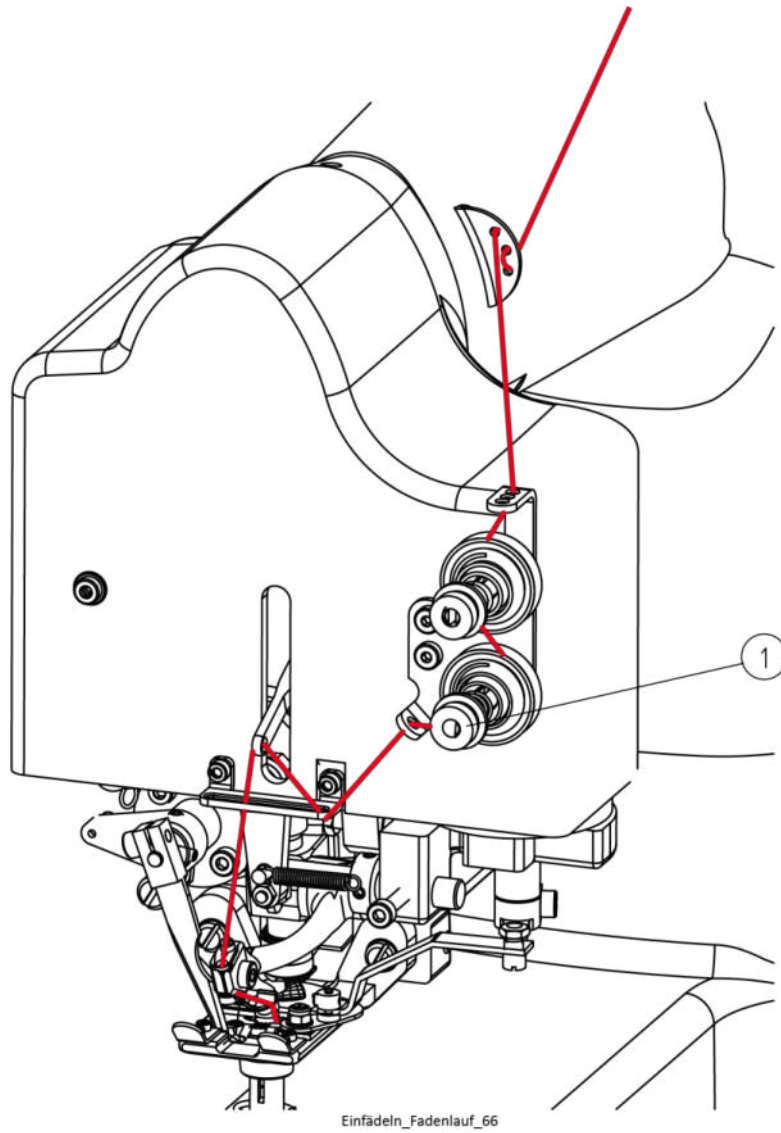

4.4 Thread tension (upper thread tension)

Depending on thread quality, nature and thickness of the thread and the fabric the thread tension is set by means of upper tension nut (1) (Fig. 7).

4.4.1 Setting the thread length at the beginning of the seam (lower thread tension)

By turning lower tension nut (1) (Fig. 7) to the right the thread length at the beginning becomes shorter, turning it to the left it becomes longer.

4.5 Stitch depth

The springloaded plunger presses the material to be sewn towards the stitch plate opening to enable the needle to penetrate the fabric layers in the desired depth.

4.5.1 Setting the stitch depth

The adjusting knob for the stitch depth setting is situated on the left hand side on the front side of the lower arm (Fig. 1).

- Turning adjusting knob backwards (anticlockwise) results in the highest plunger position and consequently in a deeper needle penetration.
- When turning the adjusting knob to the front (clockwise) the plunger is lowered and the needle penetrates the fabric less deep.

Per notch the stitch depth is altered by 0.04 mm.

Please note:!

The new spring-loaded plunger gives you more flexibility when setting the stitch depth. The spring-loaded plunger can better compensate for differences in material thickness!

4.6 Sewing drive

The machine is equipped with an Duerkopp Adler DA 432 motor and an DAC Classic control box. The necessary parameters can be found at the end of the mechanic's manual.

4.7 Use of the variable sewing tools

You will find the variable sewing tools under point 8 in the index. The class 560-31 is very versatile and offers the user a wide range of possible combinations.

Changing the sewing tools (plunger) is described in detail in the mechanic's instructions.

Examples of plunger combinations

Delivery condition:

Plunger 281.0191, Sleeve 133.0938, Pressure spring 161.0190

The factory setting is 700 Gramm

Possible combinations:

1. The spring pressure can be increased by inserting the sleeve 133.0936 and by turning the plunger set screw further to the stop, the plunger becomes stiff and no longer bounces.
2. By using pressure spring 161.0157 without sleeve, you have a strong spring pressure for thick and hard materials.
3. Kit for lapel points. The plunger 281.0192, sleeve 133.0938, pressure spring 161.0190 are used for processing lapel points on the Rever. After assembly, turn the plunger set screw to the stop until the diver is stiff and no longer bounces.



Sleeve	<p>133.0938 133.0936</p> 
Spring	<p>161.0157</p>  <p>Can be used without sleeves</p>

Fig. 8



Taucher_36

5 Operating the machine

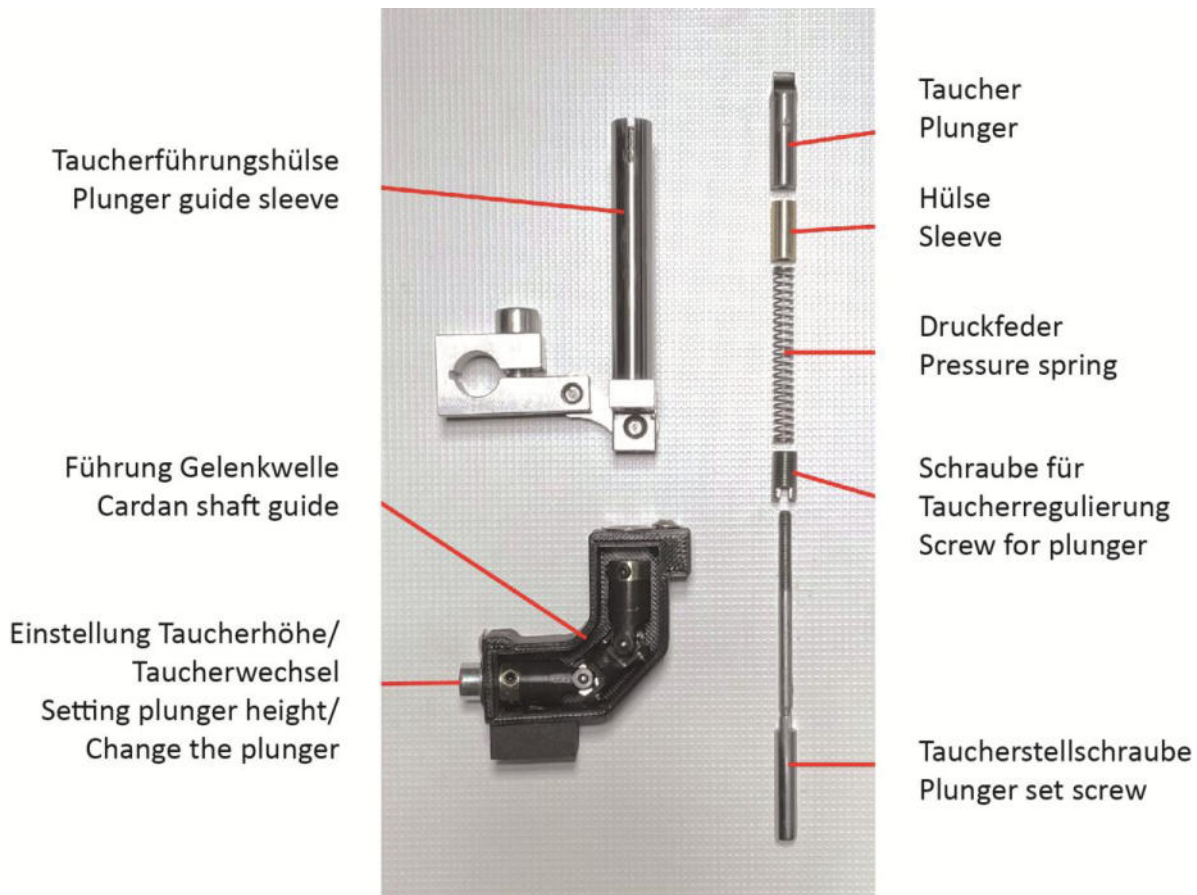
The spring-loaded plunger is pneumatically lifted. The sewing program sequence is automatic.



CAUTION ! Danger of injury!

Please observe the sewing range carefully during sewing.

Otherwise there is a **danger of injury** from crushing and needle punctures.

5.1 Switching on (Fig. 1)

Switch on control panel resp. main switch on the right hand side under the table top, the control lamp luminous.

5.2 Inserting and removing the material (Fig. 9)

To insert the sewing material, the plunger is in down position.

With pedal position + 1, the plunger with presser plate is raised, i.e. the sewing material is pressed against the stitch plate.

A readjustment can be done by lifting again (pedal position 0)

Remove the material after the sewing program (see point 4.9.1 Sewing process (Fig. 9)).

Fig. 9

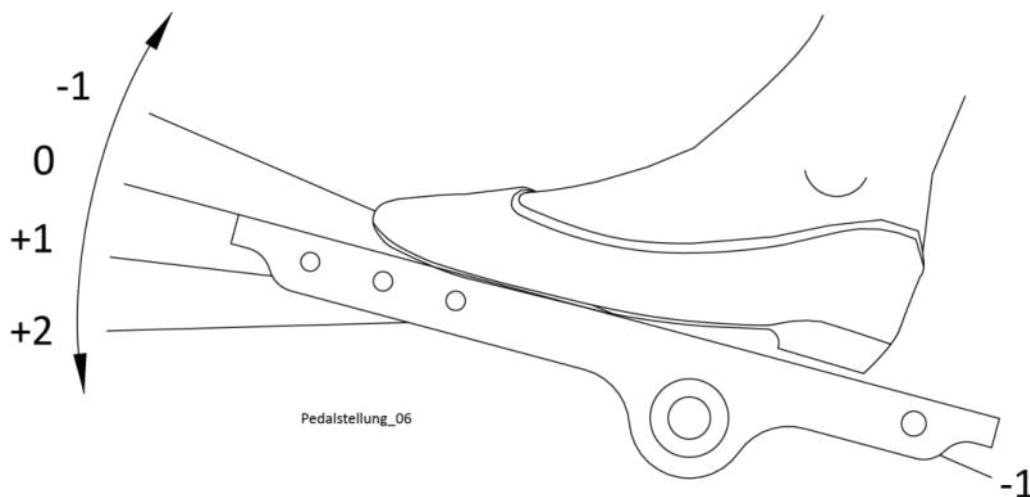

5.3 Sewing

5.3.1 Sewing process (Fig. 9)

The sewing program is activated with the pedal in two pedal positions.

Pedal position +1:

Plunger moves up to the stitch plate (can be lowered back to the starting position by pressing the pedal to pedal position 0).

Pedal level +2:

Sewing program runs automatically as follows:

- Creation of the point bartack.
- Pretensioning the thread by pulling the thread puller.
- Releasing the thread tension, pulling the starting thread to the set length by the thread puller and cutting the thread.
- Release the plunger (plunger moves downwards) if the pedal is no longer actuated.

Class 560-31 has 2 lifting variants that can be set via parameter t 40 02:

E	C	P	Min	Max	Preset value	Unit	Description
t	40	02	0	1	1	-	Foot lift Mode 0 = Foot lift not saved at sew start; 1 = Foot lift saved at sew start

Explanation of the parameter values that can be set:

t 40 02 = 0 The lifting is automatically opened at the end of the seam.

At the beginning of the seam, the lifting is closed with pedal position +1/2', but is not stored, i.e. when the pedal is in the pedal position '0', the lifting is opened again.

t 40 02 = 1 The lifting is automatically opened at the end of the seam.

At the beginning of the seam, the lifting is closed and stored in the pedal position +1/2', i.e. If the pedal is returned to '0', the lifting remains closed. The lifting can be opened at any time by moving the pedal to position '-2'.

6 Operating and function of the control

6.1 General

The control is switched on and off by the S1 power switch, which is located on the right side of the machine, below the tabletop (Fig. 10).

Fig. 10

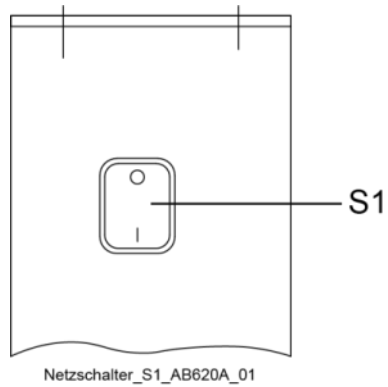

6.2 Control and display elements OP1000 (Fig. 11)

Fig. 11

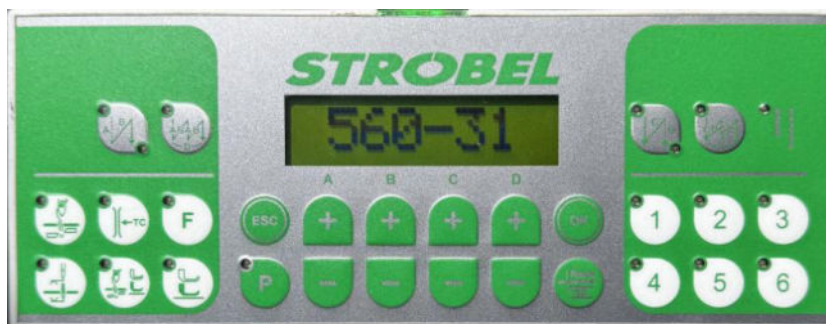

Button Function in sewing mode
(after power switch S1 on)



- P** Calling up the programming mode
The number of bartack stitches is shown on the left-hand side of the display
- A + / -** The number of bartack stitches can be set 6,8,10,12,14
- 1** The 'Sewing start' pedal control can be called up and go back to the background when pressed again
- D + / -** The pedal control is shown on the right-hand side of the display
the pedal control can be set 1 - 11 (5 = preset)

All other buttons are not used!

6.2.1 Pedal step "sewing start"

This function can be changed the pedal step "sewing start".

Valid for the setting:

- 5 → Delivery condition
- 1 - 11 → Sewing start is done via the strobel specific pedal evaluation.
The number value indicates the pedal step, from the sewing start is triggered

The function can only be outside the seam, with open the lifting, called.

6.3 Failures



CAUTION ! Danger of injury!

Switch off machine electrically and confirm that the machine is really in standstill position by operating the treadle for the motor control.

Remove the needle.

Otherwise there is a **danger of injury** from crushing and needle punctures.

● **Thread tears**

Possible Reasons:

- the thread tension is too tight
- the needle is damaged
- the looper point is damaged
- unsuitable threads are used
- the stitch plate is not polished in the range of needle penetration

Solutions:

- loosen the thread tension
- change the needle
- change the looper
- choose other threads
- repolish the stitch plate by means of an abrasive cloth

● **Stitches may skip when:**

Possible Reasons:

- the thread tension is too tight
- the looper is too high above the needle
- the thread at the beginning is too short
- the needle is bent
- the loop stroke is too small or too big
- a stitch plate with the wrong opening is used

Solutions:

- loosen the thread tension
- reset the looper
- set a longer thread at the beginning
- change the needle
- enlarge the loop stroke
- choose a suitable stitch plate

- **Insufficient knotting of the threads may happen when:**

Possible Reasons:

- the needle has reached its lower cusp point but the loop is still on the looper back

Solutions:

- repolish the looper back by means of a diamond file and an abrasive cloth

- **Insufficient needle penetration may happen when:**

Possible Reasons:

- the needle point is damaged
- the plunger is not set high enough
- the stitch plate is too small and therefore the material cannot be pressed far enough into the stitch plate
- the pressure of the clamping plate is not correct

Solutions:

- change the needle
- reset the plunger
- choose a suitable stitch plate
- if very thick material is sewn loosen the screws in setting ring, no pressure is effected on the clamping plate any more.

- **The loop may come undone when:**

Possible Reasons:

- the sewing starts with the needle penetration on the right hand side
ATTENTION: start sewing process with the needle penetration on the left hand side
(Machine on the handwheel one turn continue turning)
- the cut thread end is not hold slightly by the thread (on the stitch plate)
- loops are not knotted tight enough
- the material is hard and the thread is smooth

Solutions:

- rebend spring slightly to reduce the distance between spring and thread holder
- set upper thread tension tighter
- use a rougher covering yarn

7 Machine maintenance



CAUTION ! Danger of injury!

Switch off the machine electrically, and depress the motor switch pedal to make sure that the machine is truly switched off.

Otherwise there is a **danger of injury** from crushing and needle punctures.

8 Variable sewing tools







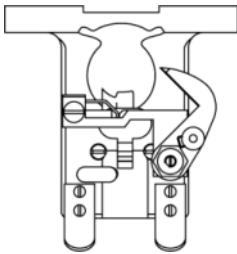
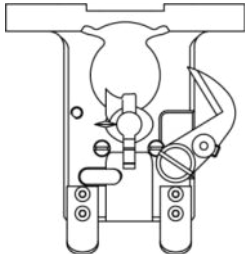
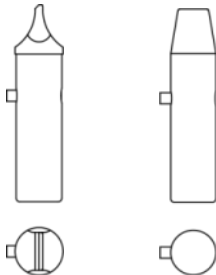
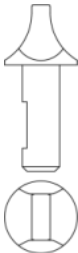

CAUTION ! Danger of injury!

Switch off the machine electrically, and depress the motor switch pedal to make sure that the machine is truly switched off.

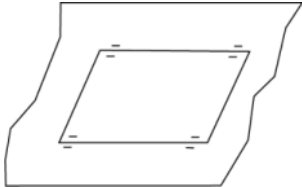
Otherwise there is a **danger of injury** from crushing and needle punctures.

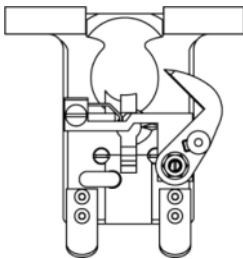
The following chart shows all sewing tools available.

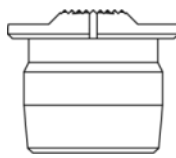
Cl. 560-31		
Stitch plate	<p>Standard 380.0271</p>  <p>8,0 mm Opening</p>	<p>for woven labels Optional 280.0279</p>  <p>4,5 mm Opening</p>
Plunger	<p>Standard 281.0191 281.0188</p> 	<p>Optional 181.0193</p> 
Sleeve	<p>Standard 133.0938 133.0936</p> 	
Spring	<p>161.0157</p>  <p>Can be used without sleeves</p>	
Stitch formation		

Cl. 560-31 - Kit for lapel points (Optional)	
Stitch plate	380.0269  4,5 mm opening
Plunger	281.0192 
Bush	133.0936
Front cup	182.0349 
Pressure spring	161.0187
Set collar	246.0216
Stitch formation	

9 **Optional extras**

213.0104 Round working plate Ø130 mm

9.1 **Special version for lapel points**

00000.3642 Kit for lapel points 560-31

Noch Fragen?

Dann rufen Sie uns an, schreiben Sie uns oder kommen Sie einfach bei uns vorbei.

Sie können jederzeit weitere Informationen über unsere Produkte anfordern oder die Strobel-Nähmaschinen in unserem Ausstellungsraum live erleben. Wir freuen uns auf Sie!

Any further questions?

Then phone, write or simply come and see us. You can have further information about our products at any time, or experience the Strobel machines live in our show room. We're looking forward to meeting you!

STROBEL

Spezialmaschinen GmbH

Postfach 1242
82168 Puchheim
Boschstraße 16
82178 Puchheim
DEUTSCHLAND

www.strobel.biz
Telefon: +49 89 80096-0
Telefax: +49 89 80096-190

Und wir können noch mehr für Sie tun!

Unser Lieferprogramm bietet für jede Branche und jegliche Anforderung genau die richtige Problemlösung.

And we can do a lot more for you!

Our range offers the correct problem solution for every branch and for all requirements.

■ Für die Bekleidungsindustrie:

Ein- und Zweifaden-Hochleistungs-Saummaschinen

Doppelblindstich-Saummaschinen

Zweifaden-Blindstich-Staffiermaschinen

Roll- und Flachpikiermaschinen

Pikier-Automat

und

weitere Spezial-Nähmaschinen

■ *For the clothing industry:*

Single and two thread high performance hemming machines

Bluff edge hemming machines

Two thread blind stitch felling machines

Roll and flat padding machines

Automatic lapel padding machine

and other special sewing machines

■ Für die Schuhverarbeitung:

Einfaden-Überwendlichmaschinen mit und ohne Differentialtransport

■ *For the shoe industry:*

Single-thread overseaming machines with and without differential feed

■ Für Kürschnereien und Pelzkonfektion:

Pelzschnellnäher

■ *For the fur industry:*

High-speed fur sewing machines

■ Für Heimtextilien:

Ein- und Zweifaden-Blindstichmaschinen

■ *For the home textiles industry:*

Single and two thread blind stitch machines

■ Für die Polsterverarbeitung:

Ein- und Zweifaden-Überwendlichmaschinen

Ein- und Zweifaden-Blindstichmaschinen

■ *For the upholstery industry:*

Single and two thread overseaming machines

Single and two thread blind stitch machines

■ Für die Konfektion technischer Textilien:

Ein- und Zweifaden-Überwendlichmaschinen

■ *For the processing of technical textiles:*

Single and two thread overseaming machines